

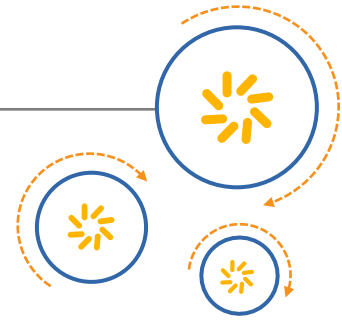

Qualcomm Technologies, Inc.



QCA6234 Integrated Dual-Band 2x2 802.11n + Bluetooth® 4.0

Data Sheet

September 2016

© 2015-2016 Qualcomm Technologies, Inc. All rights reserved.

Qualcomm Snapdragon is a product of Qualcomm Technologies, Inc. Other Qualcomm products referenced herein are products of Qualcomm Technologies, Inc. or its other subsidiaries.

DragonBoard, Qualcomm, and Snapdragon are trademarks of Qualcomm Incorporated, registered in the United States and other countries. Other product and brand names may be trademarks or registered trademarks of their respective owners.

This technical data may be subject to U.S. and international export, re-export, or transfer ("export") laws. Diversion contrary to U.S. and international law is strictly prohibited.

Use of this document is subject to the license set forth in Exhibit 1.

Qualcomm Technologies, Inc.
5775 Morehouse Drive
San Diego, CA 92121
U.S.A.

LM80-P0598-12 Rev B

Revision history

Revision	Date	Description
B	September 2016	Update for 'E' part
A	June 1, 2015	Initial release

Contents

1 Introduction	6
1.1 General description	6
1.2 Acronyms, abbreviations, and terms	7
1.3 QCA6234 features	9
2 Features Summary	11
2.1 Overview	11
2.2 Radio front end	11
2.3 Industry leading coexistence	11
2.4 Power management	11
2.5 Manufacturing calibration	12
2.6 Reference frequency	12
2.7 Internal sleep clock	12
2.8 Interfaces	12
2.9 Mobile 802.11n	12
2.10 Advanced WLAN features	13
2.10.1 AP mode (mobile hot spot)	14
2.10.2 Wi-Fi Direct (peer-to-peer)	14
2.11 Host offloading (WLAN)	14
2.12 Advanced Bluetooth	15
3 WLAN Functional Description	17
3.1 Overview	17
3.2 XTENSA CPU	17
3.3 AHB and APB blocks	18
3.4 MBOX	18
3.5 Debug UART	18
3.6 Reset control	18
3.7 Reset sequence	19
3.8 Power transition diagram	19
3.8.1 Hardware power states	19
3.8.2 Sleep state management	19
3.9 System clocking (RTC block)	21
3.9.1 High-speed clocking	21
3.9.2 Low-speed clocking	21
3.9.3 Interface clock	22
3.10 MAC/BB/RF block	22
3.11 Baseband block	22
3.12 Design for test	22
4 Bluetooth Functional Description	23
4.1 HCI-UART interface	23
4.2 PCM interface	23
4.3 CPU and memory	23
4.4 Standard WLAN coexistence	23
4.5 QTI proprietary coexistence interface	23
4.6 Reference clock	24

4.7 BT low energy	24
4.8 Reset	24
4.9 Radio	24
4.10 GPIO	24
5 Electrical Characteristics	25
5.1 Absolute maximum ratings	25
5.2 Recommended operating conditions	25
5.3 DC electrical characteristics	26
5.4 WLAN radio receiver characteristics	28
5.5 WLAN transmitter characteristics	29
5.6 Typical WLAN power consumption performance	30
5.7 Bluetooth radio characteristics	32
5.8 Typical Bluetooth power consumption performance	34
6 Pin Assignments and Descriptions	36
7 Package Dimensions	41
8 Ordering Information	43
9 Part Reliability Summary	44
10 Carriage, Storage & Handling Information	45
10.1 10.1 Carrier Tape System	45
10.1.1 Tape and Reel Information	45
10.2 Storage	46
10.2.1 Bag storage conditions	46
10.2.2 Out of Bag Duration	46
10.3 Handling	46
10.3.1 Baking	47
10.3.2 Electrostatic Discharge	47
Exhibit 1	48

Figures

Figure 1-1 QCA6234 system block diagram	6
Figure 3-1 AR6004 power state	21
Figure 5-1 Power on/off timing	26
Figure 5-2 Power on/off timing	27
Figure 6-1 QCA6234 LGA pin-out view	36
Figure 7-1 QCA6234 package top and side views	41
Figure 7-2 QCA6234 bottom view	42
Figure 10-1 Tape Orientation on Reel	45

Tables

Table 1-1 Acronyms, abbreviations, and terms	7
--	---

Table 2-1 802.11n (PHY layer) throughput at different modulations	13
Table 3-1 Power management states	20
Table 5-1 Absolute maximum ratings.....	25
Table 5-2 Recommended operating conditions.....	25
Table 5-3 General DC electrical characteristics (for 3.3 V I/O operation).....	26
Table 5-4 Timing diagram definitions	27
Table 5-5 WLAN receiver characteristics for 2.4 GHz dual chain operation, 25°C.....	28
Table 5-6 WLAN receiver characteristics for 5 GHz dual chain operation, 25°C.....	28
Table 5-7 WLAN transmitter characteristics for 2.4 GHz per chain operation, 25°C	29
Table 5-8 WLAN transmitter characteristics for 5 GHz per chain operation, 25°C	30
Table 5-9 QCA6234 typical WLAN current consumption in SDIO mode – low power states at 3.3 V operation, T _{AMBIENT} = 25°C.....	30
Table 5-10 QCA6234 typical WLAN current consumption in HSIC mode – low power states at 3.3 V operation, T _{AMBIENT} = 25°C	31
Table 5-11 Typical WLAN current consumption [2.4 GHz operation] – continuous receive at 3.3 V operation, T _{AMBIENT} = 25°C.....	31
Table 5-12 Typical WLAN current consumption [2.4 GHz operation] – continuous transmit at 3.3 V operation, T _{AMBIENT} = 25°C.....	32
Table 5-13 Typical WLAN current consumption [5 GHz operation] – continuous receive at 3.3 V operation, T _{AMBIENT} = 25°C	32
Table 5-14 Typical WLAN current consumption [5 GHz operation] – continuous transmit at 3.3 V operation, T _{AMBIENT} = 25°C	32
Table 5-15 Basic rate transmitter performance temperature at 25°C (1.8 V)	33
Table 5-16 Enhanced data rate transmitter performance 25°C (1.8 V)	33
Table 5-17 Basic rate receiver performance at 1.8 V.....	34
Table 5-18 Enhanced data rate receiver performance 1.8 V.....	34
Table 5-19 Typical Bluetooth power consumption with UART interface, AR6004 in HOST_OFF mode, BT_VDD=1.8 V, TX=0 dBm, 25°C.....	34
Table 6-1 QCA6234 pin definitions	37
Table 9-1 QCA6234 device reliability test results.....	44
Table 9-2 QCA6234 package reliability test results.....	44
Table 10-1 Reel and Protective Band Attributes	45

1 Introduction

1.1 General description

The QCA6234 chip is a complete, small form factor 2x2 802.11 a/b/g/n WLAN plus BT4.0 combo solution optimized for low-power embedded devices. The device integrates all WLAN and Bluetooth® (BT) functionality in a single package to support a low cost, layout-friendly implementation while allowing flexibility for platform specific customization.

The QCA6234 chip integrates the complete transmit/receive RF paths including baluns, switches, and a reference oscillator. The device is also pre-calibrated, eliminating the need for customer production calibration.

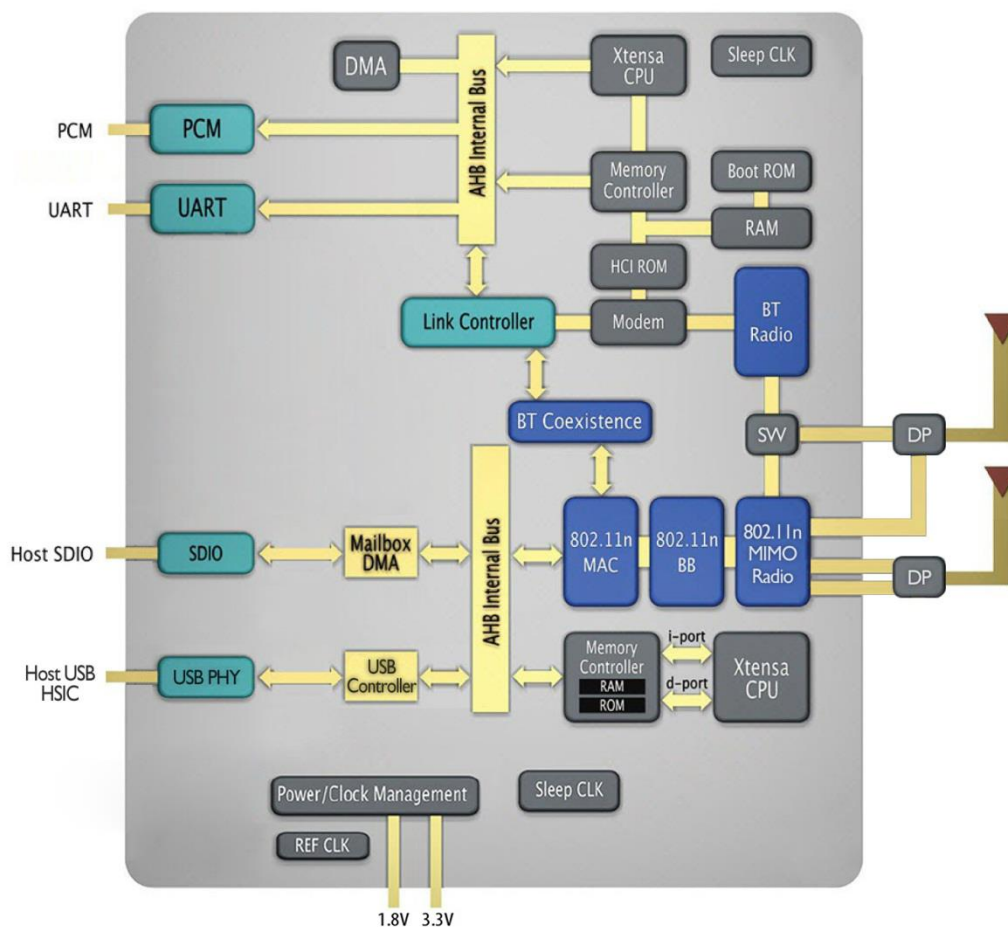

Figure 1-1 QCA6234 system block diagram

QCA6234 supports Bluetooth 2.1 + EDR and Bluetooth low energy (Bluetooth 4.0) standards enabling seamless integration of BT/WLAN and Low Energy technology. A flexible BT RAM/ROM split architecture enables optional customization to meet customer specific needs and use cases. Ultra-low power consumption radio architecture and proprietary power save technologies extend battery life. Embedded on-chip CPUs handle complete 11n and BT MAC/BB/PHY processing to minimize host processor loading.

QCA6234 is available in three variants:

- QCA6234X: 2x2, dual-band 802.11n and Bluetooth 4.0 (SDIO)
- QCA6234XH: 2x2, dual-band 802.11n and Bluetooth 4.0 (HSIC)
- QCA6234XU: 2x2, dual-band 802.11n and Bluetooth 4.0 (USB)

QCA6234 is available in a low profile 9.2 mm x 9.2 mm LGA package with 0.65 mm pitch pads for low-cost PCB design. It is halogen-free, Pb-free, and fully ROHS compliant.

NOTE: This document provides a description of chipset capabilities. Not all features are available, nor are all features supported in the software.

NOTE: Enabling some features may require additional licensing fees.

1.2 Acronyms, abbreviations, and terms

Table 1-1 provides definitions for the acronyms, abbreviations, and terms used in this document.

Table 1-1 Acronyms, abbreviations, and terms

Term	Definition
A2DP	Advanced Audio Distribution Profile
ADB	Android Debug Bridge
ADC	Analog-to-Digital Converter
ACL	Access Control List
AHB	Advanced High-Performance Bus
ANT	Antenna
AP	Access Point
APB	Advanced Peripheral Bus
ARP	Address Resolution Protocol
ATPG	Automatic Test Procedure
AVRCP	Audio/video Remote Control Profile
BB	Baseband
BPSK	Binary Phase Shift Keying
BT	Bluetooth
CODEC	Coder-Decoder
DCU	DCF control units
DMA	Direct Memory Access
DRU	DMA Receive Unit

Term	Definition
DTIM	Delivery Traffic Indication Map
EDR	Enhanced Data Rate
ESD	Electrostatic Discharge
EVM	Error Vector Magnitude
FTP	File Transfer Protocol
GAP	Generic Access Profile
HFP	Hands Free Profile
HGI	Half Guard Interval
HID	Human Interface Device
HIU	Host Interface Unit
HGI	Half Guard Interval
HSP	Head Set Profile
LDPC	Low Density Parity Check
LTE	Long Term Evolution
MAC	Message Authentication Code
Mbps	Megabits Per Second
ML	Minimum Likelihood
MPDU	Mac Protocol Data Unit
MRC	Maximum Ratio Combining
MSDU	MAC Service Data Unit
OFDM	Orthogonal Frequency Division Multiplexing
OPP	Object Push Profile
PA	Power Amplifier
PAN	Personal Area Network
PCB	Printed Circuit Board
PCU	Protocol Control Unit
PCM	Pulse Code Modulation
PD	Pull Down
PHY	Physical Layer
PIF	Peripheral Interface
PMK	Pairwise Master Key
PU	Pull Up
QCU	Queue Control Unit
QoS	Quality Of Service
RF	Radio Frequency
RH	Relative Humidity
RIFS	Reduced Inter-frame Spacing
RTC	Reverse Traffic Channel
RTT	Round Trip Time

Term	Definition
RX (Rx)	Receiver
SI	System Information
SIP	Simple IP
SDIO	Secure Digital Input Output
SPI	Serial Peripheral Interface
SPP	Serial Port Protocol
STBC	Space Time Block Coding
TCP	Transmit Control Protocol
TX (Tx)	Transmitter
UART	Universal Asynchronous Receiver Transmitter
uHAST	Unbiased Highly Accelerated Stress Test
VOIP	Voice Over Internet Protocol
WEP	Wired Equivalent Privacy
WLAN	Wireless Local Area Network
WMM	Wi-Fi Multimedia
WPA	Wi-Fi Protected Access
WPS	WLAN Protected Setup

1.3 QCA6234 features

- Two stream (2x2) 802.11n provides highest throughput and superior RF performance for embedded computing devices.
- Advanced 2x2 802.11n features:
 - 40 MHz channels at 5 GHz
 - Half guard interval (HGI) for high throughput
 - Frame aggregation for high throughput
 - Space time block coding (STBC) Rx for improved downlink robustness over range
 - Low density parity check (LDPC) encoding for improved uplink and downlink robustness over range
 - Maximum ratio combining (MRC)
 - Maximum likelihood (ML) decoder
- Supports popular interfaces used in embedded designs:
 - SDIO 2.0 (50 MHz, 4-bit and 1-bit) for WLAN
 - USB/HSIC for WLAN
 - High-speed UART (up to 4 Mbps)
- Bluetooth™ low energy (BT4.0) ready.
 - Class 1.5 Bluetooth with integrated Tx/Rx switch

- All WLAN RF transmitters are pre-calibrated.
- Near zero power consumption in idle and stand-by enables users to leave WLAN and BT *always on*.
- Advanced BT/WLAN coexistence and concurrent RX for superior rate-over-range and very low latency.
- Best in class Rx sensitivity for superior throughput rate-over-range performance.
- Integrated Sleep Clock eliminates the need for expensive bulky 32 KHz real-time clock.
- Integrated conformal RF shielding and near-zero RBOM for lowest cost.

2 Features Summary

2.1 Overview

The QCA6234 chip is a single package combination IEEE 802.11 a/b/g/n plus Bluetooth 4.0 device based on cutting edge technology from the AR6004 ROCm family of mobile 11n and AR3002 ROCm family of HCI-ROM Bluetooth devices. The QCA6234 contains dual 802.11 and Bluetooth radios, including full digital MAC and baseband engines handling all 802.11 CCK/OFDM 2.4 GHz, and Bluetooth basic rate, and EDR baseband and protocol processing. Dual embedded low-power CPU cores minimize host loading and maximize flexibility to support customer specific profiles and use cases.

2.2 Radio front end

The QCA6234 integrates the complete transmit/receive RF paths including baluns, switches, and reference oscillator. External duplexers are required for dual-band WLAN implementation.

2.3 Industry leading coexistence

The QTI proprietary WLAN/BT coexistence algorithms, proven in various devices and portable devices shipped-to-date, are designed to enable superior rate-over-range throughput and low-latency performance in various operating conditions.

The algorithms optimize important use cases such as Bluetooth monovoice audio (HSP/HFP), Bluetooth stereo audio (A2DP), and Bluetooth data transfer profiles (OPP, FTP, etc.) in parallel with WLAN traffic including concurrent operation of BT2.1+EDR and BT-LE cases.

The use cases are optimized to provide the highest WLAN throughput, long range, and low power consumption while maintaining excellent Bluetooth audio quality, high data throughput, and low-latency. The flexible hardware and software architecture of the QCA6234 is also designed to help deployment of customization and enhancements of the coexistence algorithm to support any future use cases.

2.4 Power management

The QCA6234 can run on one 3.3 volt power supply and an I/O supply of 1.8V. Both WLAN and Bluetooth power management utilize advanced power saving techniques such as: gating clocks to idle or inactive blocks; voltage scaling to specific blocks in certain states; fast start and settling circuits to reduce Tx; active duty cycles, CPU frequency scaling, and other techniques to optimize power consumption across all operating states.

QCA6234X and QCA6234XH versions are designed to use the internal 1.2V switching regulator. However, QCA6234XU version must use an external 1.2V supply for both the analog and digital 1.2V domain.

2.5 Manufacturing calibration

The QCA6234 is fully RF system tested and calibrated in production, simplifying the radio testing on the customer production line, and eliminating the need for calibration.

2.6 Reference frequency

The QCA6234 incorporates a 26 MHz reference frequency source in-package. Internally, the system reference frequency is sleep regulated and gated to enable the internal crystal to be powered down when the device is in sleep mode. Manufacturing calibration of the crystal is not required.

2.7 Internal sleep clock

The QCA6234 incorporates integrated on-chip low power sleep clocks to regulate internal timing, eliminating the need for any external 32 KHz real-time clocks or crystal oscillators.

2.8 Interfaces

The QCA6234 supports industry standard WLAN and Bluetooth host interfaces:

- SDIO 2.0 (50 MHz, 4-bit and 1-bit) for WLAN
- USB/HSIC for WLAN
- HS-UART for Bluetooth HCI (Host Controller Interface) and is compatible with any upper layer Bluetooth stack

2.9 Mobile 802.11n

The QCA6234 incorporates the latest generation of mobile 802.11n technology from QTI. The QCA6234 is 802.11n compliant and features:

- Half Guard Interval for high throughput
- Frame Aggregation for high throughput
- Space Time Block Coding (STBC) Rx for improved downlink robustness over range
- Low Density Parity Check (LDPC) for improved uplink and downlink robustness over range

[Table 2-1](#) shows the 802.11n (PHY layer) throughput at different modulations.

Table 2-1 802.11n (PHY layer) throughput at different modulations

Mode	MCS	Modulation	Data Rate (Mbps)	
			20 MHz Channel	
			FGI ¹	SGI ²
IEEE 802.11n	0	BPSK	6.5	7.2
	1	QPSK	13.0	14.4
	2	QPSK	19.5	21.7
	3	16-QAM	26.0	29.9
	4	16-QAM	39.0	43.3
	5	64-QAM	52.0	57.8
	6	64-QAM	58.5	65.0
	7	64-QAM	65.0	72.2
	8	BPSK	13.0	14.4
	9	QPSK	26.0	28.9
	10	QPSK	39.0	43.3
	11	16-QAM	52.0	57.8
	12	16-QAM	78.0	86.7
	13	64-QAM	104.0	115.6
	14	64-QAM	117.0	130.0
15	64-QAM	130.0	144.4	

2.10 Advanced WLAN features

The QCA6234 is fully compliant with IEEE 802.11e QoS, Wi-Fi Alliance® WMM Power Save, and 802.11n power saving, ensuring the lowest possible power consumption.

Advanced features such as Host wake-on-wireless and ARP (address resolution protocol) off-loading enable the WLAN link to remain associated for extended periods with host processor asleep for additional deep system power savings.

The QCA6234 features hardware-based AES, AES-CCMP, and TKIP engines for faster data encryption, and supports industry leading security features including Cisco CCXv4 ASD, WAPI (for China), WLAN Protected Setup (WPS), along with standard WEP/WPA/WPA2 for personal and enterprise environments.

¹ Full Guard Interval = 800 ns

² Short Guard Interval = 400 ns

Other WLAN features include:

- WWR, 802.11d, 802.11h
- WLAN Protected Setup (WPS)
- Wi-Fi CERTIFIED Wi-Fi Direct®
- RTT (Round Trip Time) for indoor locationing
- Device based scanning and roaming, tunable parameters optimized for seamless handover
- Statistics and events for monitoring
- Self-managed power state handling
- Self-contained beacon processing
- Shared authentication
- Ad-hoc power save
- Multiple PMK ID support
- Simulated UAPSD
- T-Spec support
- Production flow diagnostics
- Dynamic PS-Polling for enhanced coexistence performance with Bluetooth
- QoS support for VoIP applications
- Bluetooth 3.0 HS (High Speed) 802.11 AMP (Alternate MAC PHY)

2.10.1 AP mode (mobile hot spot)

The QTI industry leading AP Mode feature allows the QCA6234 device to operate as both a station and an Access Point, enabling seamless station-to-station interconnection with all the benefits of standard infrastructure-level simplicity (no special client software or settings required), security, and power save functionality. The AP Mode enables the deployment of unique and powerful applications such as mobile 3G gateway and mobile range extension.

2.10.2 Wi-Fi Direct (peer-to-peer)

The QTI industry leading Wi-Fi Direct implementation of advanced peer-to-peer connectivity enables faster device-to-device data and media transfer, improved network efficiency eliminating the ‘hop’ through the access point, simultaneous connection to device and the Internet, and simple PAN setup (with WLAN Protected Setup), all with reduced power consumption to extend battery life.

2.11 Host offloading (WLAN)

The QCA6234 integrates extensive hardware signal processing and an embedded on-chip CPU to offload complete 11n MAC/BB/PHY processing to minimize host processor loading and support application specific customization for gaming and mobile phones.

The QCA6234 offloads the complete 802.11 b/g/n baseband and MAC functions as a standard feature, including:

- Link maintenance
- 802.11 frame transmission sequence to initiate the connection with an access point
- Background scanning, including transmission of probe request
- Signal quality detection and automated maintenance of current access point list
- Roaming to a new access point
- Rate adaptation including automatic retry
- Encapsulation of 802.3 frames from the host to 802.11 frames, including adding the security headers for 802.11
- De-capsulation of the 802.11 frame to 802.3 frame
- Encryption and decryption (hardware ciphers) for WEP/TKIP/AES-CCMP, and WAPI
- IEEE PowerSave, periodic wakeup when in sleep mode to check for buffered traffic
- Packet Filtering and Host Wakeup, including ARP (Address Resolution Protocol) response; automated filtering of received data in the sleep mode to transfer only data packets of interest to the host
- Frame Aggregation (A-MPDU) processing
- LDPC encode/decode and STBC decode
- Additionally, the QCA6234 also provides host offloading of the following advanced features:
 - TCP checksum
 - Security negotiation: perform initial and subsequent 4-way handshake offload and initial Group Key exchange and Re-Keying

2.12 Advanced Bluetooth

The QCA6234 incorporates an integrated low-power Bluetooth radio, supporting all mandatory and optional features. Advanced architecture and protocol techniques, including DMA off-load, clock gating and clock scaling, and hardware-based page/inquiry scan, enable very low power operation in all states and modes.

The QCA6234, for Linux-based OS, supports all standard profiles on BlueZ stack, including (but not limited to):

- GAP: generic access profile
- SPP: serial port profile
- HSP: headset profile
- HFP: hands-free profile
- A2DP: advanced audio distribution profile
- AVRCP: audio/video remote control profile
- FTP: File transfer profile
- PAN: personal area networking profile

- OPP: object push profile
- HID: human interface device profile

The flexible RAM/ROM based architecture enables custom or future profiles to be easily added.

3 WLAN Functional Description

3.1 Overview

The QCA6234 WLAN block is based on the AR6004—the latest generation of the QTI 802.11n chipset optimized for low power embedded applications. It is configured to operate in dual-band, two-stream (2x2) mode.

Frame aggregation, reduced inter-frame spacing (RIFS), and half guard intervals provide improved throughput on the link. The WLAN chipset provides a robust communication environment, capable of supporting space time block codes (STBC) and Low Density Parity Check (LDPC) codes. Additional 11n performance optimizations, such as 11n frame aggregation (A-MPDU and A-MSDU) are provided by drivers that support SDIO bus transaction bundling (a form of bus aggregation) and low-overhead host assisted buffering (RX A-MSDU and RX A-MPDU).

These techniques can improve the performance and efficiency of applications involving large bulk data transfers (for example, file transfers or high-resolution video streaming). The typical data path consists of the host interface, mailbox DMA, AHB, memory controller, MAC, BB, and radio. The CPU drives the control path via register and memory accesses. External interfaces include USB LPM/HSIC, SDIO, and JTAG. See [Figure 3-1](#) for details.

3.2 XTENSA CPU

At the heart of the chip is the XTENSA CPU. The CPU is connected to a large 288 Kb RAM block, which precludes the need of external memory. The CPU has 512 Kb internal ROM. The CPU connects to the main AHB bus through its peripheral interface (PIF). It also has a JTAG interface for debugging.

The CPU's internal logic and boot code are designed to detect the presence of an external host and to automatically begin communicating with that host. The CPU communicates directly with the RAM and ROM modules within the device without any caching. Boot code in the 512 Kb ROM first detects the presence of an external host. It then begins communicating with this host.

3.3 AHB and APB blocks

The AHB block acts as an arbiter on the AHB bus and arbitrates requests from various components of the chip. Depending upon the address, the AHB data request can go into one of the two slaves: the APB block or the CPU PIF. Data requests to the CPU PIF are generally high-speed memory requests, while requests to the APB block are primarily meant for register access.

The APB block acts as a decoder. It is meant only for access to programmable registers within the AR6004's main blocks. Depending on the address, the APB request can go to one of the places listed below:

- Radio
- SI/SPI
- MBOX
- GPIO
- UART
- RTC
- MAC/BB

3.4 MBOX

The MBOX is a service module to handle the external SDIO host. The MBOX has two interfaces:

- an APB interface for access to the MBOX registers
- an AHB interface, which is used by the external host to access the MC memory or other registers within the AR6004

3.5 Debug UART

The QCA6234 includes a high-speed Universal Asynchronous Receiver/Transmitter (UART) interface that is fully compatible with the 16550 UART industry standard. This UART is a general purpose UART although it is primarily used for debug. Only the TXD is brought out to a pin, however.

3.6 Reset control

WLAN_PWD_L and BT_PWD_L pins need to be asserted low to completely reset both Wi-Fi and Bluetooth. After these signals have been de-asserted, the QCA6234 waits for host communication. Until then, the MAC, BB, and SOC blocks are powered off and all modules except the host interface are held in reset.

Once the host has initiated communication, the QCA6234 turns on its crystal and later its PLL. After all clocks are stable and running, the resets to all blocks are automatically de-asserted. The Bluetooth function should be powered down/reset whenever WLAN is reset because it derives its clock from WLAN.

3.7 Reset sequence

After a COLD_RESET event (for example, the host toggles CHIP_PWD_L) the AR6004 will enter the HOST_OFF state and await communication from the host. From that point, the typical AR6004 COLD_RESET sequence is as follows:

1. When the host is ready to use the AR6004, it initiates communication via SDIO.
2. The AR6004 enters the WAKEUP state, then the ON state, and enables the XTENSA CPU to begin executing ROM code. Software configures the AR6004 functions and interfaces. When the AR6004 is ready to receive commands from the host, it will set an internal function ready bit.
3. The host reads the ready bit and can now send function commands to the AR6004.
4. The CPU may continue to be held in reset under some circumstances until its reset is cleared by an external pin or when the host clears a register.
5. The MAC cold reset and the MAC/BB warm reset will continue to stay asserted until their respective reset registers are cleared by software.

3.8 Power transition diagram

The QCA6234 provides integrated power management and control functions and extremely low power operation for maximum battery life across all operational states by:

- Gating clocks for logic when not needed
- Shutting down unneeded high speed clock sources
- Reducing voltage levels to specific blocks in some states

Figure 3-1 depicts the power state transition diagram.

3.8.1 Hardware power states

AR6004 hardware has five top-level hardware power states managed by the RTC block. Table 3-1 describes the input from the MAC, CPU, SDIO/MBOX, interrupt logic, and timers that affect the power states.

3.8.2 Sleep state management

Sleep state minimizes power consumption while saving system states. In SLEEP state, all high speed clocks are gated off and the external reference clock source is powered off. For the AR6004 to enter SLEEP state, the MAC, MBOX, and CPU systems must not be active.

The system remains in sleep state until a WAKEUP event causes the system to enter WAKEUP state; wait for the reference clock source to stabilize, and then ungate all enabled clock trees. The CPU wakes up only when an interrupt arrives, which may have also generated the system WAKEUP event.

Table 3-1 Power management states

State	Description
OFF	CHIP_PWD_L pin assertion immediately brings the chip to this state.
	Sleep clock is disabled.
	No state is preserved.
HOST_OFF	WLAN is turned off. The Bluetooth clock is off, but should also be powered down through BT_PWD_L.
	Only the host interface is powered on, the rest of the chip is power gated (off).
	The host instructs the AR6004 to transition to WAKEUP by writing a register in the host interface domain.
	Embedded CPU and WLAN do not retain state (separate entry).
	For USB/HSIC or hostless designs, this state can be bypassed by asserting FORCE_HOST_ON_L during CHIP_PWD_L de-assertion.
SLEEP	Only the sleep clock is operating.
	The crystal or oscillator is disabled.
	Any wakeup events (MAC, host, LF-Timer, GPIO-interrupt) will force a transition from this state to the WAKEUP state.
	All internal states are maintained.
WAKEUP	The system transitions from sleep states to ON.
	The high frequency clock is gated off as the crystal or oscillator is brought up and the PLL is enabled.
	WAKEUP duration is programmable.
ON	The high speed clock is operational and sent to each block enabled by the clock control register.
	Lower level clock gating is implemented at the block level, including the CPU, which can be gated off using the WAIT instruction while the system is on. No CPU, host, and WLAN activities will transition to sleep states. WLAN must be initialized prior to Bluetooth initialization and use.

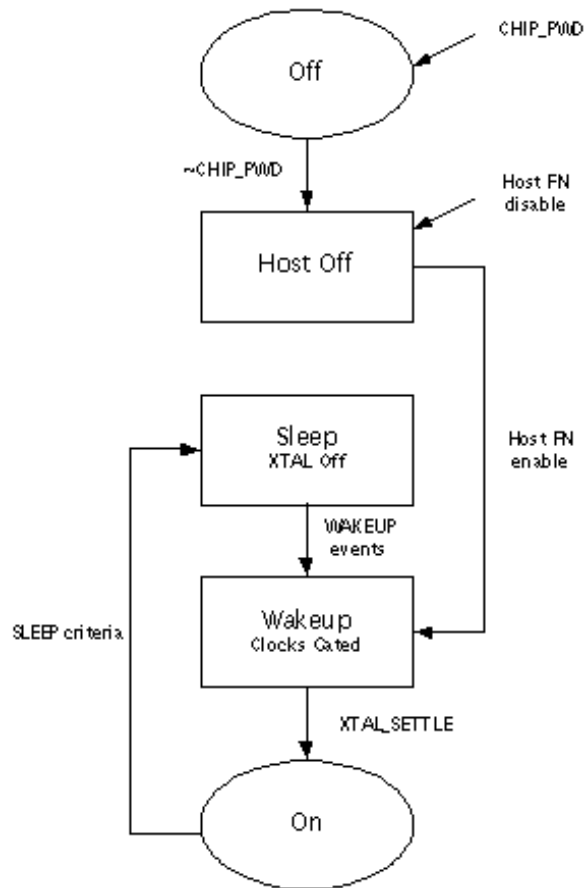

Figure 3-1 AR6004 power state

3.9 System clocking (RTC block)

The AR6004 has an RTC block that controls the clocks and power going to other internal modules. Its inputs consist of sleep requests from these modules and its outputs consist of clock enable and power signals, which are used to gate the clocks going to these modules. The RTC block also manages resets going to other modules with the device. The AR6004's clocking is grouped into two types: high-speed and low-speed.

3.9.1 High-speed clocking

The reference 26 MHz clock source inside the QCA6234 drives the PLL and RF synthesizer of Wi-Fi and Bluetooth. To minimize power consumption, the reference clock source is powered off in SLEEP, HOST_OFF, and OFF states.

3.9.2 Low-speed clocking

The AR6004 has eliminated the need for an external sleep clock source, thereby reducing system cost. Instead, an internal ring oscillator is used to generate a low frequency sleep clock. It is also used to run the state machines and counters related to low power states.

The AR6004 has an internal calibration module that produces a 32.768 KHz output with minimal variation. For this, it uses the reference clock source as the golden clock. As a result, the calibration module adjusts for process and temperature variations in the ring oscillator when the system is in ON state.

The AR6004 also supports using an external low frequency sleep clock source in applications where one is already available.

3.9.3 Interface clock

The host interface clock represents another clock domain for the AR6004. This clock comes from the SDIO and is completely independent from the other internal clocks. It drives the host interface logic as well as certain registers, which can be accessed by the host in HOST_OFF and SLEEP states.

3.10 MAC/BB/RF block

The AR6004 wireless MAC consists of five major blocks:

- Host interface unit (HIU) for bridging to the AHB for bulk data accesses and APB for register accesses
- Ten queue control units (QCU) for transferring TX data
- Ten DCF control units (DCU) for managing channel access
- Protocol control unit (PCU) for interfacing to baseband
- DMA receive unit (DRU) for transferring RX data

3.11 Baseband block

The AR6004 baseband module (BB) is the physical layer controller for the 802.11b/g/n air interface. It is responsible for modulating data packets in the transmit direction, and detecting and demodulating data packets in the receive direction. It has a direct control interface to the radio to enable hardware to adjust analog gains and modes dynamically.

3.12 Design for test

The AR6004 has a built-in JTAG boundary scan of its pins. It also has features that enable testing of digital blocks via ATPG scan, memories via MBIST, analog components, and the radio.

4 Bluetooth Functional Description

The QCA6234 Bluetooth (BT) block is based on the QTI AR3002 and described in the following sections.

4.1 HCI-UART interface

The UART interface is a standard high speed UART interface, being able to operate up to 4 Mbps, supporting Bluetooth HCI UART interface.

4.2 PCM interface

A PCM interface to an external mono-audio CODEC is supported. The BT block supports CODECs: Winbond W681360, Wolfson WM8974, and Realtek ALC5620. The PCM supports both 8 KHz/16 KHz frequencies.

The BT block can operate as the PCM interface master generating an output clock or configured as a PCM interface slave. It supports 13-bit, 16-bit, 8-bit, or 14-bit μ -law, A-law, or linear mono-sample formats at 8K, 16K, 32K, 48K, 64K, and 96K sample(s).

4.3 CPU and memory

The BT block uses a 32-bit RISC core with five-stage pipelining and 16-bit and 24-bit instruction encoding. On startup, the BT block boots from the boot ROM. Software checks OTP first for configuration information. It then gets configuration from the host and proceeds to execute from on-chip ROM.

4.4 Standard WLAN coexistence

The QCA6234 supports internally the standard WLAN coexistence interface through the WLAN_ACTIVE, BT_PRIORITY, and BT_ACTIVE pins.

4.5 QTI proprietary coexistence interface

The QTI proprietary interface enables increased information sharing between the Bluetooth and WLAN blocks. The interface allows the same information exchange as the on-chip interface of a single chip solution. Additional interface HW allows synchronizing the timing of the two devices. The timing synchronization and additional information enables superior WLAN and Bluetooth scheduling for increased throughput, longer range, better audio quality, and lower power consumption.

4.6 Reference clock

The BT block is configured for 26 MHz reference clock frequency. The clock source is provided to BT internally from the WLAN block on demand from BT_CLK_REQ. The WLAN block must be initialized before BT clock sharing is enabled.

4.7 BT low energy

The QCA6234 supports low energy specification, which allows for connection to devices with single mode LE function, for example, Watch, Sensor, and HID. The implementation is optimized for coexistence with WLAN.

4.8 Reset

The pin BT_PWD_L resets and powers down the BT block.

Holding the BT_PWD_L pin at GND turns off the entire BT block and all state information is lost.

All core supply voltages are internally gated off in this condition to minimize leakage.

The power-on-reset (POR) circuit detects a low-to-high transition on this pin and executes a reset after BT_VDD has stabilized.

4.9 Radio

The BT radio shares the single antenna port with WLAN through an internal 3-way RF switch. The QCA6234 implements WLAN/BT coexistence internally.

BT_VDDPA provides power to the BT PA and must be connected to the same supply voltage as BT_VDD at 1.8 V.

4.10 GPIO

A single output pin BT_LED is provided to drive an indicator LED. This pin indicates Bluetooth activity and status.

The BT_DISABLE pin is not used and should be connected to ground.

5 Electrical Characteristics

5.1 Absolute maximum ratings

Table 5-1 summarizes the absolute maximum ratings and Table 5-2 lists the recommended operating conditions for the QCA6234. Absolute maximum ratings are those values beyond which damage to the device can occur.

Functional operation under these conditions, or at any other condition beyond those indicated in the operational sections of this document, is not recommended.

NOTE: Maximum rating for signals follows the supply domain of the signals.

Table 5-1 Absolute maximum ratings

Symbol (Domain)	Parameter	Max Rating	Unit
SDIO_IOVDD	WLAN host interface I/O supply	-0.3 to 4.0	V
IOVDD, BT_IOVDD	WLAN and BT GPIO I/O power supply	-0.3 to 4.0	V
VBAT_VDD33	External 3.3 V power supply	-0.3 to 4.2	V
VDD33	External 3.3 V power supply	-0.3 to 4.0	V
VDD33_REG	External 3.3 V power supply	-0.3 to 3.65	V
BT_VDD	BT Power core supply	3.6	V
BT_VDDPA	BT PA supply	3.6	V
T _{STORE}	Storage Temperature	-45 to +125	°C
ANT_2G	Maximum RF input (reference to 50-Ω input)	+10	dBm
ESD	Electrostatic discharge tolerance		
	5G TX1	1000	V
	All other pins	1500	V

5.2 Recommended operating conditions

Table 5-2 Recommended operating conditions

Symbol (Domain)	Parameter	Min	Typ	Max	Unit
SDIO_IOVDD	WLAN host interface I/O supply	1.71	1.8/3.3	3.46	V
IOVDD	WLAN GPIO I/O power supply	1.71	1.8	3.46	V
BT_IOVDD	BT GPIO I/O power supply	1.71	1.8/3.3	3.46	V
VBAT_VDD33	External 3.3 V power supply	3.14	3.30	3.46	V
VDD33	External 3.3 V power supply	3.14	3.30	3.46	V
VDD33_REG	External 3.3 V power supply	3.14	3.30	3.46	V
BT_VDD	BT core supply	1.71	1.8	1.98	V

Symbol (Domain)	Parameter	Min	Typ	Max	Unit
BT_VDDPA	BT PA supply	1.71	1.8	1.98	V
T _{ambient}	Ambient temperature	-20	25	85	°C

5.3 DC electrical characteristics

Table 5-3 lists the general DC electrical characteristics over recommended operating conditions (unless otherwise specified).

Table 5-3 General DC electrical characteristics (for 3.3 V I/O operation)

Symbol	Parameter	Conditions	Min	Typ	Max	Unit
V _{IH}	High Level Input Voltage		0.7 x V _{DD}			V
V _{IL}	Low Level Input Voltage				0.3 x V _{DD}	V
I _{IL}	Input Leakage Current	Without Pull-up or Pull-down 0 V < V _{IN} < V _{DD} 0 V < V _{OUT} < V _{DD}	0		-3	nA
		With Pull-up 0 V < V _{IN} < V _{DD} 0 V < V _{OUT} < V _{DD}	16		48	μA
		With Pull-down 0 V < V _{IN} < V _{DD} 0 V < V _{OUT} < V _{DD}	-14		-47	μA
V _{OH}	High Level Output Voltage	I _{OH} = -4mA	0.9 x V _{DD}			V
		I _{OH} = -12mA	0.9 x V _{DD}			V
V _{OL}	Low Level Output Voltage	I _{OH} = 4mA			0.1 x V _{DD}	V
		I _{OH} = 12mA			0.1 x V _{DD}	V

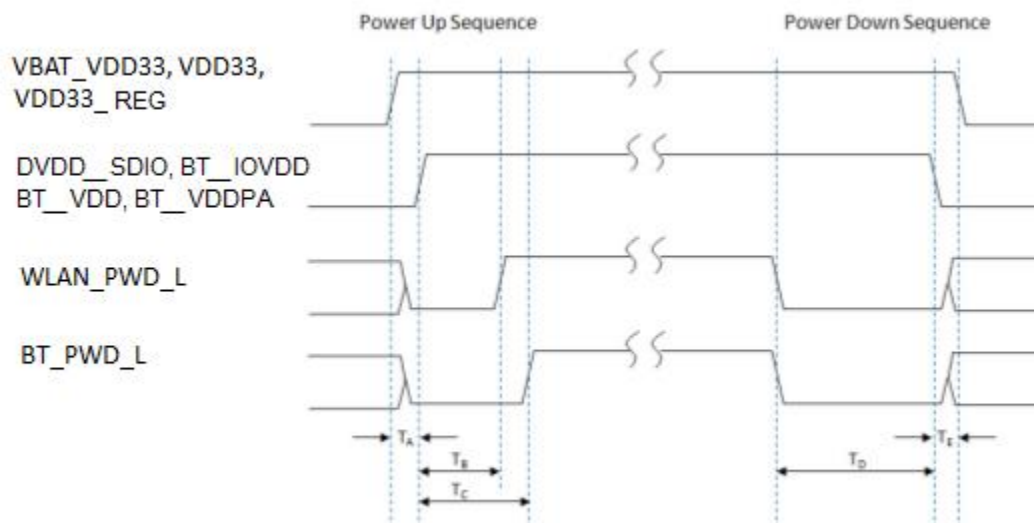

Figure 5-1 Power on/off timing

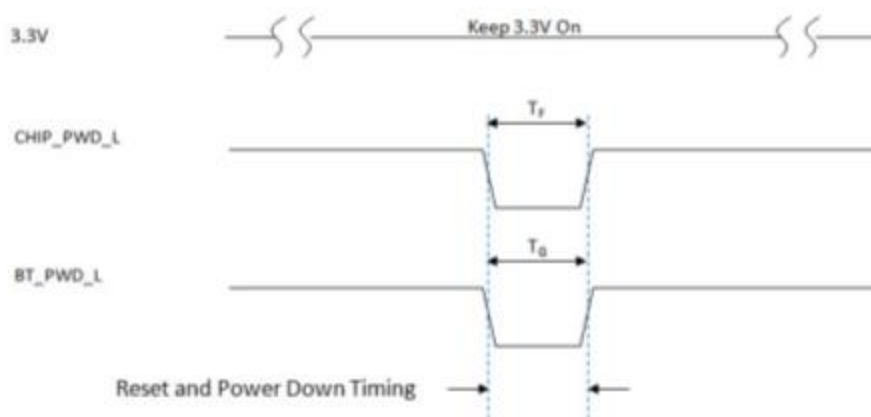

Figure 5-2 Power on/off timing

Table 5-4 Timing diagram definitions

Timing	Description	Min	Unit
T _a	Time between 3.3V and VIO supplies	0	μsec
T _b	Time between VIO supplies valid, SD_CMD, SD_D2, and SD_D1 SDIO lines pulled high to VIO, and WLAN_PWD_L negation. The pull-up on SD_CMD, SD_D2, and SD_D1 configures SDIO mode on boot-up upon negation of WLAN_PWD_L.	5	μsec
T _c	Time between VIO supplies valid and BT_PWD_L negation.	5	msec
T _d	Time between WLAN_PWD_L assertion and VIO invalid, or time between BT_PWD_L negation and VIO invalid.	0	μsec
T _e	Time between VIO invalid and 3.3 V invalid.	No requirement	
T _f	Time of WLAN_PWD_L assertion during reset or power down period. Both 3.3 V and VIO should keep ON.	5	μsec
T _g	Time of BT_PWD_L assertion during reset or power down period. Both 3.3 V and VIO should keep ON.	5	msec

QCA6234 requires SDIO interface lines SD_CMD, SD_D1, and SD_D2 to be high prior to negation of WLAN_PWD_L. Designs should drive these lines high, or if necessary, add external pull-ups to ensure proper SDIO configuration on WLAN boot-up. Failure to pull these lines high will result in non-functional SDIO interface. These are boot-mode straps interpreted by the WLAN CPU on power-on.

5.4 WLAN radio receiver characteristics

Table 5-5 and Table 5-7 summarize the WLAN QCA6234 receiver characteristics. $V_{DD33} = 3.3$ V and $T_{AMBIENT} = 25^{\circ}\text{C}$, unless otherwise specified.

Table 5-5 WLAN receiver characteristics for 2.4 GHz dual chain operation, 25°C

Symbol	Parameter	Conditions	Min	Typ	Max	Unit
F_{rx}	Receive input frequency range		2.412		2.484	GHz
S_{rf}	Sensitivity					
	CCK, 1 Mbps	See Note ³		-98		dBm
	CCK, 11 Mbps			-91		
	OFDM, 6 Mbps			-94		
	OFDM, 18 Mbps			-90		
	OFDM, 36 Mbps			-83		
	OFDM, 54 Mbps			-78		
	HT20, MCS0			-94		
	HT20, MCS3			-86		
	HT20, MCS5			-79		
	HT20, MCS7		-74	-76		
	HT20, MCS8			-92		
	HT20, MCS11			-83		
	HT20, MCS13			-76		
	HT20, MCS15			-72		
R_{adj}	Adjacent channel rejection					
	OFDM, 6 Mbps	See Note ⁴		32		dB
	OFDM, 54 Mbps			16		
	HT20, MCS0			31		
	HT20, MCS7			14		

Table 5-6 WLAN receiver characteristics for 5 GHz dual chain operation, 25°C

Symbol	Parameter	Conditions	Min	Typ	Max	Unit
F_{rx}	Receive input frequency range		5.180		5.925	GHz
S_{rf}	Sensitivity					
	OFDM, 6 Mbps	See Note ⁵		-92		dBm
	OFDM, 18 Mbps			-89		
	OFDM, 36 Mbps			-82		
	OFDM, 54 Mbps			-76		
	HT20, MCS0			-93		
	HT20, MCS3			-84		

- ³ Performance numbers are referenced to the QCA6234 device pin under Dual Chain Operation.
- ⁴ Performance numbers are referenced to the QCA6234 device pin under Dual Chain Operation.
- ⁵ Performance numbers are referenced to the QCA6234 device pin under Dual Chain Operation.

Symbol	Parameter	Conditions	Min	Typ	Max	Unit
	HT20, MCS5			-79		
	HT20, MCS7		-70	-73		
	HT20, MCS8			-92		
	HT20, MCS11			-83		
	HT20, MCS13			-75		
	HT20, MCS15			-72		
	HT40, MCS0			-90		
	HT40, MCS3			-81		
	HT40, MCS5			-76		
	HT40, MCS7			-69		
	HT40, MCS8			-89		
	HT40, MCS11			-79		
	HT40, MCS13			-71		
	HT40, MCS15			-68		
	R_{adj}		Adjacent channel rejection			
	OFDM, 6 Mbps	See Note ⁶		22		dB
	OFDM, 54 Mbps			9		
	HT20, MCS0			20		
	HT20, MCS7			19		

5.5 WLAN transmitter characteristics

Table 5-8 and Table 5-9 summarize the transmitter characteristics for QCA6234. $V_{DD33} = 3.3\text{ V}$ and $T_{AMBIENT} = 25^{\circ}\text{C}$, unless otherwise specified.

Table 5-7 WLAN transmitter characteristics for 2.4 GHz per chain operation, 25°C

Symbol	Parameter	Conditions	Min	Typ	Max	Unit
F_{tx}	Transmit output frequency range		2.412		2.484	GHz
P_{out}	Output power	See Note ⁷				dBm
	11b mask compliant	1 Mbps	17.5	19.0	20.5	
	11g mask compliant	6 Mbps		18.0		

⁶ Performance numbers are referenced to the QCA6234 device pin under Dual Chain Operation.

⁷ Performance numbers are referenced to the QCA6234 device pin under Single Chain Operation.

Dual Chain Operation will typically provide 3 dB higher output power.

Refer to IEEE Std 802.11--2012 specification for transmit spectrum limits:

- 802.11b mask (17.4.7.4)
- 802.11g mask (18.3.9.3)
- 802.11g EVM (20.3.20.7.3)
- 802.11n HT20 mask (20.3.20.1)
- 802.11n HT20 EVM (20.3.20.7.3)

Symbol	Parameter	Conditions	Min	Typ	Max	Unit
	11g EVM compliant	54 Mbps	14.0	15.5	17.0	
	11n HT20 mask compliant	MCS0	15.0	16.5	18.0	
	11n HT20 EVM compliant	MCS7	12.5	14.0	15.5	
	11n HT20 EVM compliant	MCS15		12.5		
A _{TX}	Transmit power accuracy	-	-	-	±1.5	dB

Table 5-8 WLAN transmitter characteristics for 5 GHz per chain operation, 25°C

Symbol	Parameter	Conditions	Min	Typ	Max	Unit
F _{tx}	Transmit output frequency range		5.180		5.925	GHz
P _{out}	Output power	See Note ⁸				dBm
	11a mask compliant	6 Mbps		17		
	11a EVM compliant	54 Mbps	11.5	13.5	15.5	
	11n HT20 mask compliant	MCS0	15.5	17.5	19.5	
	11n HT20 EVM compliant	MCS7	10.5	12.5	14.5	
	11n HT20 EVM compliant	MCS15		10.5		
	11n HT40 mask compliant	MCS0		14.5		
	11n HT40 EVM compliant	MCS7		12.0		
11n HT40 EVM compliant	MCS15		10.5			
A _{TX}	Transmit power accuracy	-	-	-	±2.0	dB

5.6 Typical WLAN power consumption performance

Table 5-9 QCA6234 typical WLAN current consumption in SDIO mode – low power states at 3.3 V operation, T_{AMBIENT} = 25°C

Mode		VDD33 (mA) Single Chain	DVDD_SDIO (mA)	VDD33 (mA) Dual Chain	DVDD_SDI O (mA)
Standby	OFF	0.007	0	0.007	0
	HOST_OFF	0.050	0.04	0.050	0.04
	SLEEP	0.250	0.05	0.250	0.05
	DTIM=1	2.28	0.10	2.75	0.10

⁸ Performance numbers are referenced to the QCA6234 device pin under Single Chain Operation.

Dual Chain Operation will typically provide 3 dB higher output power.

Refer to IEEE Std 802.11--2012 specification for transmit spectrum limits:

- 802.11b mask (17.4.7.4)
- 802.11g mask (18.3.9.3)
- 802.11g EVM (20.3.20.7.3)
- 802.11n HT20 mask (20.3.20.1)
- 802.11n HT20 EVM (20.3.20.7.3)

Mode		VDD33 (mA) Single Chain	DVDD_SDIO (mA)	VDD33 (mA) Dual Chain	DVDD_SDI O (mA)
IEEE PS, 2.4 GHz	DTIM=3	1.02	0.08	1.14	0.08
	DTIM=10	0.52	0.06	0.56	0.06
IEEE PS, 5 GHz	DTIM=1	1.33	0.10	1.43	0.10
	DTIM=3	0.64	0.08	0.65	0.08
	DTIM=10	0.40	0.06	0.41	0.06

Table 5-10 QCA6234 typical WLAN current consumption in HSIC mode – low power states at 3.3 V operation, T_{AMBIENT} = 25°C

Mode		VDD33 (mA) Single Chain	DVDD_SDIO (mA)	VDD33 (mA) Dual Chain	DVDD_SDI O (mA)
Standby	OFF	0.007	0	0.007	0
	SLEEP	0.400	0.05	0.400	0.05
IEEE PS, 2.4 GHz	DTIM=1	3.41	0.10	3.82	0.10
	DTIM=3	1.46	0.08	1.59	0.08
	DTIM=10	0.77	0.06	0.81	0.06
IEEE PS, 5 GHz	DTIM=1	1.68	0.10	1.78	0.10
	DTIM=3	0.88	0.08	0.91	0.08
	DTIM=10	0.60	0.06	0.61	0.06

Table 5-11 Typical WLAN current consumption [2.4 GHz operation] – continuous receive at 3.3 V operation, T_{AMBIENT} = 25°C

Mode/Rate [Mbps]	Typical Current Consumption Single Chain (mA) ⁹	Typical Current Consumption Dual Chain (mA) ¹⁰
RX, 1 Mbps	65	77
RX, 11 Mbps	66	77
RX, 54 Mbps	69	81
RX, HT20 MCS0	67	74
RX, HT20 MCS7	69	83
RX, HT20 MCS15	--	88

⁹ With LPL enabled.

¹⁰ With LPL enabled.

Table 5-12 Typical WLAN current consumption [2.4 GHz operation] – continuous transmit at 3.3 V operation, T_{AMBIENT} = 25°C

Mode/Rate [Mbps]	Output Power Per Chain [dBm] ¹¹	Typical Current Consumption Single Chain (mA)	Typical Current Consumption Dual Chain (mA)
TX, 1 Mbps	19.0	300	542
TX, 6 Mbps	18.0	276	491
TX, 54 Mbps	15.5	250	446
TX, HT20 MCS0	16.5	250	446
TX, HT20 MCS7	14.0	205	350

Table 5-13 Typical WLAN current consumption [5 GHz operation] – continuous receive at 3.3 V operation, T_{AMBIENT} = 25°C

Mode/Rate [Mbps]	Typical Current Consumption Single Chain (mA)	Typical Current Consumption Dual Chain (mA)
RX, 54 Mbps	75	82
RX, HT20 MCS0	79	87
RX, HT20 MCS7	81	89
RX, HT20 MCS15	--	91
RX, HT40 MCS0	91	105
RX, HT40 MCS7	93	107
RX, HT40 MCS15	--	115

Table 5-14 Typical WLAN current consumption [5 GHz operation] – continuous transmit at 3.3 V operation, T_{AMBIENT} = 25°C

Mode/Rate [Mbps]	Output Power Per Chain [dBm] ¹²	Typical Current Consumption Single Chain (mA)	Typical Current Consumption Dual Chain (mA)
TX, 6 Mbps	17.0	342	640
TX, 54 Mbps	13.5	300	541
TX, HT20 MCS0	17.5	343	626
TX, HT20 MCS7	12.5	297	534
TX, HT40 MCS0	14.5	333	604
TX, HT40 MCS7	12.0	287	503

5.7 Bluetooth radio characteristics

Table 5-15 through Table 5-18 describe the basic rate transmitter performance, enhanced data transmitter performance, basic rate receiver performance, enhanced rate receiver performance, and current consumption conditions at 25°C.

¹¹ RF power referenced at the SiP output.

¹² RF power referenced at the SiP output.

Table 5-15 Basic rate transmitter performance temperature at 25°C (1.8 V)

Test Parameter	Min	Typ	Max	Bluetooth Specification	Unit
RF Output Power Range	4.5	7.5	10.5		dBm
RF Power Control Range	32	34	36	≥ 16	dB
RF Power Control Step Size	3	4	5	$2 \leq \text{Step Size} \leq 8$	dB
Frequency Range	2.4	—	2.4835	$2.4 < f < 2.4835$	GHz
20 dB Bandwidth	—	950	—	≤ 1000	KHz
Adjacent Channel TX Power $F = F_0 \pm 2$ MHz	—	-49	—	≤ -20	dBm
Adjacent Channel TX Power $F = F_0 \pm 3$ MHz	—	-50	—	≤ -40	dBm
$\Delta f1$ avg Maximum Modulation	—	164	—	$140 < \Delta f1 \text{ avg} < 175$	KHz
$\Delta f2$ max Minimum Modulation	—	144	—	≥ 115	KHz
$\Delta f2$ avg/ $\Delta f1$ avg	—	0.88	—	≥ 0.80	—
Initial Carrier Frequency	—	0	—	$\leq \pm 75$	KHz
Drift Rate	—	0	—	≤ 20	KHz/ 50 μ s
Drift (DH1 packet)	—	1	—	≤ 25	KHz
Drift (DH5 packet)	—	-1	—	≤ 40	KHz

Table 5-16 Enhanced data rate transmitter performance 25°C (1.8 V)

Test Parameter	Min	Typ	Max	Bluetooth Specification	Unit
Relative Transmit Power	-2	0	0.5	-4 to +1	dBm
Max Carrier Frequency Stability $ w_0 $	$\pi/4$ DQPSK	—	0	$\leq \pm 10$	KHz
	8 DPSK	—	0		
Max Carrier Frequency Stability $ w_i $	$\pi/4$ DQPSK	—	0	$\leq \pm 75$	KHz
	8 DPSK	—	0		
Max Carrier Frequency Stability $ w_0+w_i $	$\pi/4$ DQPSK	—	0	$\leq \pm 75$	KHz
	8 DPSK	—	0		
RMS DEVM	$\pi/4$ DQPSK	—	6	≤ 20	%
	8 DPSK	—	6	≤ 13	%
Peak DEVM	$\pi/4$ DQPSK	—	16	≤ 35	%
	8 DPSK	—	17	≤ 25	%
99% DEVM	$\pi/4$ DQPSK	—	99.9	$99\% \leq 30$	%
	8 DPSK	—	99.9	$99\% \leq 20$	%
EDR Differential Phase Encoding	—	100	—	≥ 99	%
Adjacent Channel Power	$F \geq \pm 3$ MHz	—	-42.5	< -40	dBm
	$F = \pm 2$ MHz	—	-39	≤ -20	dBm
	$F = \pm 1$ MHz	—	-40	≤ -26	dB

Table 5-17 Basic rate receiver performance at 1.8 V

Test Parameter		Min	Typ	Max	Bluetooth Specification	Unit
Sensitivity	BER \leq 0.1%	—	-91	—	\leq -70	dBm
Maximum Input	BER \leq 0.1%	-20	—	—	\geq -20	dBm
Carrier-to-Interferer Ratio (C/I)	Co-Channel	—	—	11	11	
	Adjacent Channel (\pm 1 MHz)	—	—	0	0	dB
	Second Adjacent Channel (\pm 2 MHz)	—	—	-30	-30	dB
	Third Adjacent Channel (\pm 3 MHz)	—	—	-40	-40	dB
Maximum Level of Intermodulation Interferers		—	—	-39	< -39	dBm

Table 5-18 Enhanced data rate receiver performance 1.8 V

Test Parameter		Min	Typ	Max	Bluetooth Specification	Unit
Sensitivity (BER \leq 0.01%)	$\pi/4$ DQPSK	—	-92	—	\leq -70	dBm
	8 DPSK	—	-87	—	\leq -70	dBm
Maximum Input (BER \leq 0.1%)	$\pi/4$ DQPSK	-20	—	—	\geq -20	dBm
	8 DPSK	-20	—	—	\geq -20	dBm
Co-Channel C/I (BER \leq 0.1%)	$\pi/4$ DQPSK	—	—	13	\leq \pm 13	dB
	8 DPSK	—	—	20	\leq \pm 20	dB
Adjacent Channel C/I (BER \leq 0.1%)	$\pi/4$ DQPSK	—	—	0	\leq 0	dB
	8 DPSK	—	—	5	\leq 5	dB
Second Adjacent Channel C/I (BER \leq 0.1%)	$\pi/4$ DQPSK	—	—	-30	\leq -30	dB
	8 DPSK	—	—	-25	\leq -25	dB
Third Adjacent Channel C/I (BER \leq 0.1%)	$\pi/4$ DQPSK	—	—	-40	\leq -40	dB
	8 DPSK	—	—	-33	\leq -33	dB

5.8 Typical Bluetooth power consumption performance

Table 5-19 Typical Bluetooth power consumption with UART interface, AR6004 in HOST_OFF mode, BT_VDD=1.8 V, TX=0 dBm, 25°C

Mode for Current Consumption	AR3002 1.8 V current (mA)	AR6004 IO current (mA)	AR6004 3.3 V current (mA)
Idle Mode	0.093	0.05	0
Inquiry Scan (1.28 sec)	0.485	0.05	0.015
Page Scan (1.28 sec)	0.485	0.05	0.015
Page and Inq Scan (1.28 sec)	0.877	0.05	0.03

Mode for Current Consumption	AR3002 1.8 V current (mA)	AR6004 IO current (mA)	AR6004 3.3 V current (mA)
ACL Sniff without Scan (1.28 sec Interval, 2 Attempts) ¹³	0.116	0.05	0.06
ACL Slave ¹⁴	12.0	0.05	1.5
Inquiry	22.0	0.05	1.5
DH1 Master	25.0	0.05	1.5
DH1 Slave	25.0	0.05	1.5
DH5 Master	37.0	0.05	1.5
DH5 Slave	34.0	0.05	1.5
3DH1 Master	29.0	0.05	1.5
3DH1 Slave	29.0	0.05	1.5
3DH5 Master ¹⁵	45.0	0.05	1.5
3DH5 Slave ¹⁶	35.0	0.05	1.5
HV3 Master	17.0	0.05	1.5
HV3 Slave	19.0	0.05	1.5
2EV3 Master	15.0	0.05	1.5
2EV3 Slave	17.0	0.05	1.5
Tx-Continuous (100% Duty Cycle) ¹⁷	46.0	0.05	1.5
Rx-Continuous (100% Duty Cycle) ¹⁸	42.0	0.05	1.5

¹³ Assuming 1 msec of correlation window.

¹⁴ ACL as slave means QCA6234 is in a link (as slave) with another device, only minimum traffic to maintain link.

¹⁵ 3DH5 master: QCA6234 sends a 3DH5 packet to the slave, and the slave returns a null packet.

¹⁶ 3DH5 slave: QCA6234 receives a 3DH5 packet from the master and returns a null packet.

¹⁷ Average power during Tx burst, 0 dBm target power, 25°C.

¹⁸ Average power during Rx burst, 0 dBm target power, 25°C.

6 Pin Assignments and Descriptions

This chapter describes the pin assignment of the QCA6234.

The following nomenclature is used for signal description described in this chapter.

NC	No Connection should be made to this pin
_L	Suffix at the end of the signal name indicating active low signal
A_I/O	Analog signal
I	Digital input signal
PU	Weak internal pull-up, input can be left floating (not connected)
PD	Weak internal pull-down, input can be left floating (not connected)
I/O	A digital bidirectional signal
O	A digital output signal
P	A power or ground pin
N/A	Not applicable
X	Indeterminate, floating inputs must be externally driven high or low

DOT	1	2	3	4	5	6	7	8	9	10	11	12	13
A	SWREG_OUT	VDD33_PMU	WLAN_TDD	WLAN_TMS	AVDD12	DVDD12	GND	IOVDD	BT_IOVDD	PAREG_BASE	VBAT_VDD33	VDD33	VDD33
B	SWREG_OUT	VDD33_PMU	WLAN_TDI	WLAN_TCK	AVDD12	DVDD12	GND	VDD12_USB	VDD33_USB		PAREG_FB	VDD33	VDD33
C	SDIO_IOVDD	USB_D+/HSIC_DATA										GND	GND
D	WLAN_PWD_L	USB_D-/HSIC_STROBE										GND	2G_ANT1
E	SD_CMD	SD_D3			GND	GND	GND	GND	GND			GND	GND
F	SD_D2	SD_D1			GND	GND	GND	GND	GND			GND	5G_ANT1
G	SD_D0	SD_CLK			GND	GND	GND	GND	GND			GND	GND
H	CLK_REQ_OUT/WCN_PRIORITY	CLK_REQ_IN			GND	GND	GND	GND	GND			TM0	
J	DEBUG_UART_TXD	WAKE_ON_WLAN			GND	GND	GND	GND	GND			TM1	BT_VDD
K	BT_FREQ	WLAN_ACTIVE										GND	BT_VDDPA
L	BT_ACTIVE	BT_PRIORITY										BT_WKUP_HOST	BT_DISABLE
M	GPIO10/LTE_FRAME_SYNC	AR6004_GPIO38	GND	GND	GND	GND	GND	PCM_SYNC	PCM_OUT	BT_UART_CTS	GND	BT_UART_RXD	BT_WKUP_BT
N		LTE_ACTIVE	GND	2G_ANT0	GND	5G_ANT0	GND	PCM_BCLK	PCM_IN	BT_UART_RTS	BT_LED	BT_UART_TXD	BT_PWD_L

Figure 6-1 QCA6234 LGA pin-out view

Table 6-1 QCA6234 pin definitions

Grid	Signal Name	Description	Type	Reset State	I/O Pad Supply Domain
Power Supplies					
C1	DVDD_SDIO	WLAN Host IO (SDIO) power supply input; 1.8 V	P	N/A	N/A
A8	IOVDD	WLAN VIO power supply input; 1.8 V	P	N/A	N/A
A11	VBAT_VDD33	WLAN VBAT supply input. Connect to 3.3 V.	P	N/A	N/A
A10	PAREG_BASE	PAREG gate control output.	O	N/A	N/A
B11	PAREG_FB	Signal should be connected to 3.3 V output of external pass transistor when using PAREG.	P	N/A	N/A
A12,A13, B12,B13	VDD33	WLAN 3.3 V power supply input to WLAN PA.	P	N/A	N/A
A1,B1	SWREG_OUT	On-chip 1.2V switching regulator inductor. No connect for USB version (6234XU)	P	N/A	N/A
A6,B6	DVDD12	WLAN internal digital 1.2 V input fed from switching regulator filter.	P	N/A	N/A
A5,B5	AVDD12	WLAN internal analog 1.2 V input fed from switching regulator filter.	P	N/A	N/A
A2,B2	VDD33_REG	WLAN 3.3 V power supply input to on-chip 1.2 V switching regulator.	P	N/A	N/A
J13	BT_VDD	BT core power supply input. 1.8 V. Must be same as BT_IOVDD.	P	N/A	N/A
K13	BT_VDDPA	Power supply for BT PA. Must be same as BT_IOVDD.	P	N/A	N/A
A9	BT_IOVDD	BT VIO power supply input. Must be same voltage as IOVDD due to internal interconnection between WLAN and BT.	P	N/A	N/A
B8	VDD12_USB	Serial interface 1.2 V input fed from switching regulator filter.	P	N/A	N/A
B9	VDD33_USB	Serial interface 3.3 V input. Connect to 3.3 V.	P	N/A	N/A
See pin-out	GND	Ground	P	N/A	N/A
WLAN Host Interface					
G2	SD_CLK	SDIO Clock signal	I	Hi-Z	SDIO_IOVDD

Grid	Signal Name	Description	Type	Reset State	I/O Pad Supply Domain
E1	SD_CMD	SDIO Command signal, must be pulled externally high prior to WLAN_PWD_L negation to boot properly in SDIO mode	I/O		SDIO_IOVDD
G1	SD_D0	SDIO Data[0]	I/O		SDIO_IOVDD
F2	SD_D1	SDIO Data[1], must be pulled externally high prior to WLAN_PWD_L negation to boot properly in SDIO mode	I/O		SDIO_IOVDD
F1	SD_D2	SDIO Data[2] signal, must be pulled high prior to WLAN_PWD_L negation to boot properly in SDIO mode	I/O		SDIO_IOVDD
E2	SD_D3	SDIO Data[3] signal	I/O		SDIO_IOVDD
D1	WLAN_PWD_L	WLAN Power Down (0=power down, 1=WLAN awake). Negation samples boot strap pins for SDIO interface mode.	I, PD	Low	SDIO_IOVDD
J2	GPIO9	GPIO pin, typically used as Wake-On-Wireless (WOW): WLAN output signal to wake up host, active high.	I/O, PD	Low	IOVDD
C2	USB_D_POS	High speed serial interface, positive input for USB 2.0 mode. Also data line for HSIC mode.	I/O		USB/HSIC
D2	USB_D_NEG	High speed serial interface, negative input for USB 2.0 mode. Also strobe line for HSIC mode.	I/O		USB/HSIC
BT Host Control Interface					
N13	BT_PWD_L	BT Chip power-down control; driving this pin active low powers down or resets the BT. Signal has internal weak pull-up. BT_PWD_L should be active low at least for 5ms.	I, PU	High	BT_IOVDD
M13	BT_HOST_WKUP	Host wake-up BT.	I	High	BT_IOVDD
L12	BT_WKUP_HOST	BT wake-up host.	O	High	BT_IOVDD
N11	BT_LED	BT GPIO pin: SW can be re-configured for BT_LED.	O, PU	High	BT_IOVDD
L13	BT_DISABLE	This pin is not used. Connect to ground.			
BT UART Interface					
N10	UART_RTS	BT UART Request-To-Send. High during reset, Low after Reset. Internal pull-down.	O	High	BT_IOVDD

Grid	Signal Name	Description	Type	Reset State	I/O Pad Supply Domain
M12	UART_RXD	BT UART receive data. Signal goes low during reset, Tri-state after reset.	I	Low	BT_IOVDD
M10	UART_CTS	BT UART Clear-To-Send.	I	High	BT_IOVDD
N12	UART_TXD	BT UART Transmit Data	O, PU	High	BT_IOVDD
BT PCM Interface					
N9	PCM_IN	CODEC interface Input data. High on Reset, Low after reset. Weak pull-down.	I, PD	Low	BT_IOVDD
M9	PCM_OUT	CODEC interface Output data. High on Reset, Low after reset.	O, PD	Low	BT_IOVDD
M8	PCM_SYNC	CODEC interface synchronization control, input for slave, output for master. High on Reset, Low after reset.	I/O, PD	Low	BT_IOVDD
N8	PCM_BCK	CODEC interface bit clock, input for slave, output for master. High on Reset, Low after reset.	I/O, PD	Low	BT_IOVDD
WLAN/BT Debugging					
J1	DEBUG_UART_TXD	WLAN debugging UART TXD (GPIO11)	O	High	IOVDD
K1	BT_FREQ	Internal WLAN/BT coex control lines, test observability only; do not connect or use. Can be configured as BT JTAG.			
K2	WLAN_ACTIVE	Internal WLAN/BT coex control lines, test observability only; do not connect or use. Can be configured as BT JTAG.			
L1	BT_ACTIVE	Internal WLAN/BT coex control lines, test observability only; do not connect or use. Can be configured as BT JTAG.			
L2	BT_PRIOR	Internal WLAN/BT coex control lines, test observability only; do not connect or use. Can be configured as BT JTAG.			
M1	GPIO10	WLAN GPIO 10	I,PU	High	IOVDD
RF Interface - RF ports					
N4	2G_ANT0	WLAN/RF 2.4 GHz Antenna Port for chain 1	A_I/O	N/A	N/A
N6	5G_ANT0	WLAN/RF 5 GHz Antenna Port for chain 1	A_I/O	N/A	N/A
D13	2G_ANT1	WLAN/RF 2.4 GHz Antenna Port for chain 2	A_I/O	N/A	N/A
F13	5G_ANT1	WLAN/RF 5 GHz Antenna Port for chain 2	A_I/O	N/A	N/A

Grid	Signal Name	Description	Type	Reset State	I/O Pad Supply Domain
Clock - BT Clock					
H2	GPIO7	Internal BT Clock Request signal. It has internal connection from BT to WLAN GPIO7. Do not use this pin, leave as No connect. Useful only for test.	I/O	Low	IOVDD
H1	GPIO37	LTE co-existence signal WCN_PRIORITY.	O, PU	High	IOVDD
BT Loopback					
H12	BT_TM0	Bluetooth test mode. Do not connect.			
J12	BT_TM1	Bluetooth test mode. Do not connect.			
WLAN Boundary Scan					
A4	WLAN_TMS	No Connect (NC)			
B4	WLAN_TCK	No Connect (NC)			
B3	WLAN_TDI	No Connect (NC)			
A3	WLAN_TDO	No Connect (NC)			
LTE Co-existence					
N2	GPIO36	LTE co-existence signal LTE_ACTIVE			
N1	GPIO35	LTE co-existence signal LTE_FRAME_SYNC			
M2	GPIO38	Reserved			

7 Package Dimensions

Figure 7-1 shows the top and side views of QCA6234 (with height).

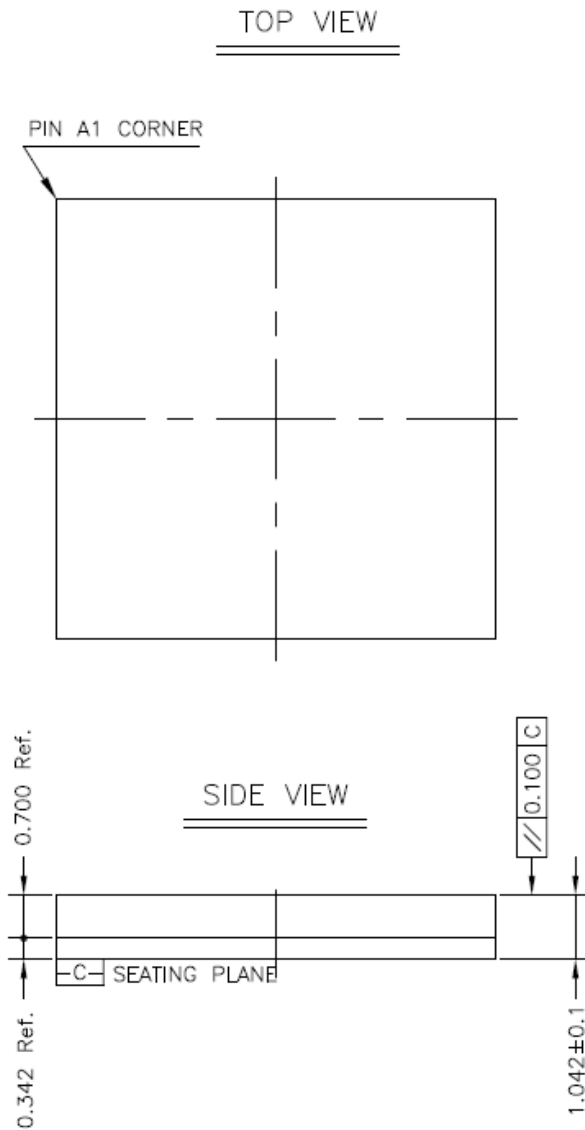
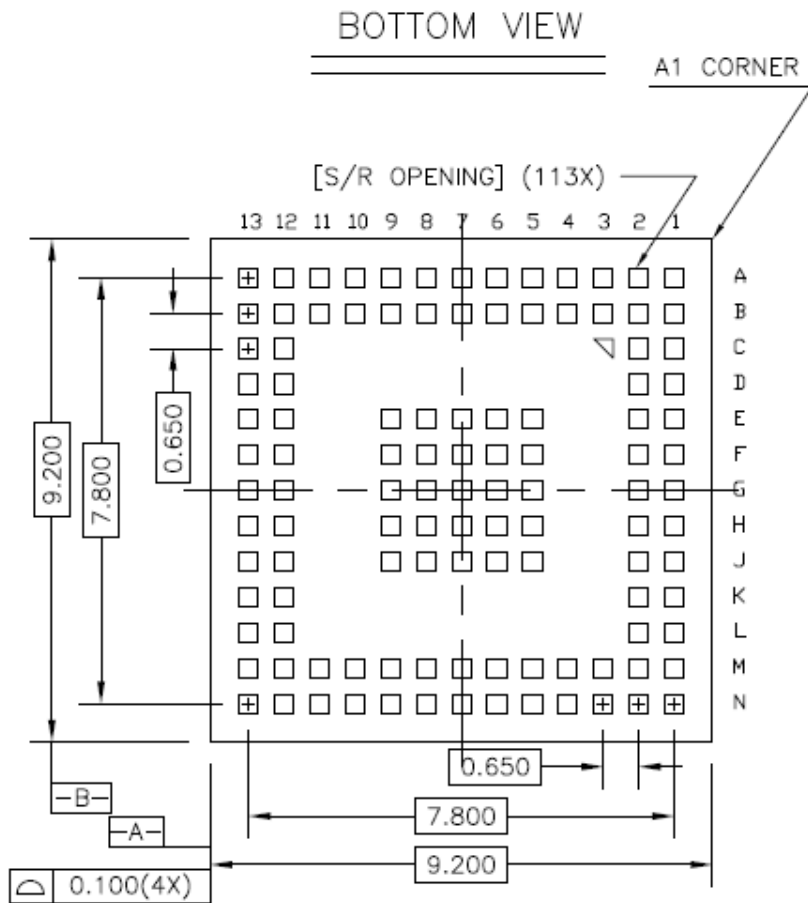

Figure 7-1 QCA6234 package top and side views

Figure 7-2 shows the bottom view of QCA6234 (with x-y dimensions).



Lead Pitch:	0.650
Lead Size:	0.350 x 0.350

Dimensions in mm.

Figure 7-2 QCA6234 bottom view

8 Ordering Information

This product can be ordered as:

- SDIO interface version:
 - QCA6234X-AM2D
 - QCA6234X-AM2D-R (Tape and Reel, Qty = 2Ku)
 - QCA6234XW-AM2D*
 - QCA6234XW-AM2D-R* (Tape and Reel, Qty = 2Ku)
 - QCA6234X2-AM2D*
 - QCA6234X2-AM2D-R* (Tape and Reel, Qty = 2Ku)
- HSIC interface version:
 - QCA6234XH-AM2D
 - QCA6234XH-AM2D-R (Tape and Reel, Qty = 2Ku)
- USB interface version
 - QCA6234XU-AM2D
 - QCA6234XU-AM2D-R (Tape and Reel, Qty = 2Ku)

* Contact your local QTI representative for availability.

9 Part Reliability Summary

Table 9-1 QCA6234 device reliability test results

Tests, Standards, and Conditions	Sample Size	Result
ESD – Human-body model (HBM) rating JESD22-A114 Target: 2000 V. (Total samples from one wafer lot)	1x3	±1.5KV PASS all pins, Except 5G Tx1 pass ±1KV
ESD – Charge-device model (CDM) rating JESD22-C101 Target: 500 V (Total samples from one wafer lot)	1x3	±500V PASS

Table 9-2 QCA6234 package reliability test results

Tests, Standards, and Conditions	Sample Size	Result
Preconditioning: J-STD-020, JESD22-A113 MSL 1, reflow temperature: 260C+0/-5°C (Total samples from three different assembly lots)	3x154	PASS
Temperature cycle: (after Preconditioning) JESD22-A104 -55°C to +125°C; 1000 cycles 2 cycles per hour (Total samples from three different assembly lots)	3x77	PASS
Unbiased Highly accelerated stress test (uHAST): (after Preconditioning) JESD22-A118, JESD22-A113 cond. A, 130C, 96 hours (Total samples from three different assembly lots)	3x77	PASS
High-Temperature Storage Life: JESD22-A103 Temperature 150°C, 1000 hours duration (Total samples from three different assembly lots)	3x77	PASS

10 Carriage, Storage & Handling Information

This chapter describes carrier tape system, tape and reel, and storage requirements for the QCA6234. See [Table 10-1](#).

10.1 10.1 Carrier Tape System

Table 10-1 Reel and Protective Band Attributes

Units per Reel	Tape Width	Tape Pitch	Reel Diameter	Hub Diameter
2000	24 mm	12 mm	330 mm	178 mm

10.1.1 Tape and Reel Information

The single-feed carrier for the QCA6234 device is illustrated in [Figure 10-1](#) which shows the tape orientation on reel. [Figure 10-2](#) shows the part orientation on tape.

The carrier tape and reel features comply to the EIA-481 standard.

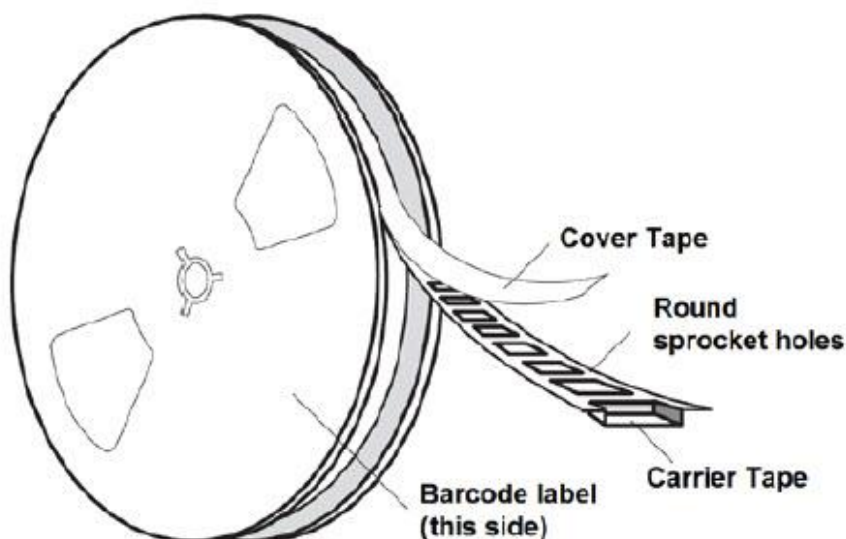

Figure 10-1 Tape Orientation on Reel

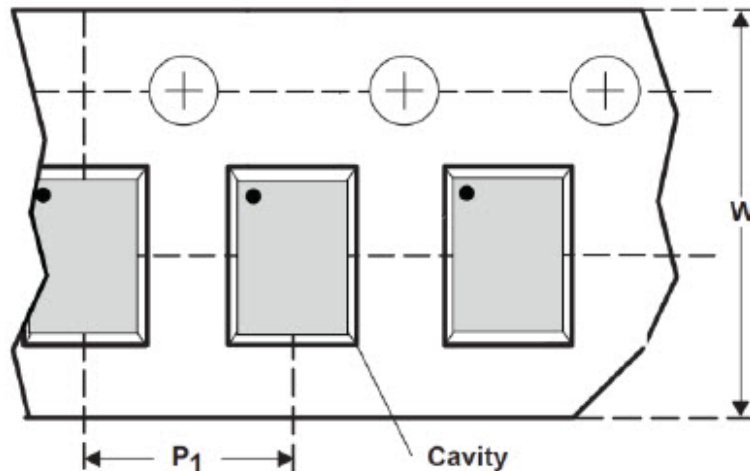

Figure 10-2 Device Orientation in Tape: Left/Q1

10.2 Storage

10.2.1 Bag storage conditions

The packages described in this document must be stored in a nitrogen-purged, sealed moisture barrier antistatic bag. The Qualcomm-calculated shelf life in a sealed moisture bag is 60 months at $< 40^{\circ}\text{C}$ and $< 90\%$ relative humidity (RH). Qualcomm recommends the following shipping and storage conditions for the CSP reel inside the sealed bag:

- Relative humidity between 15% and 70%
- Temperature – Room temperature lower than 30°C
- Atmosphere – A nitrogen dry cabinet is highly preferred

Devices should not be baked in tapes and reels at the temperatures described in this section, or at any other temperatures.

10.2.2 Out of Bag Duration

After unpacking, the package must be soldered to the PCB within the factory floor life according to the MSL rating when factory conditions are $< 30^{\circ}\text{C}$ and $< 60\%$ RH, as specified in the *IPC/JEDEC-STD-033* standard.

10.3 Handling

In addition to the storage guidelines described above, the following handling guidelines should be followed.

To eliminate damage to the silicon die due to improper handling, the following recommendations should be followed:

- Do not use tweezers, as that may cause damage to the silicon die. Qualcomm recommends using a vacuum tip to handle the device.

- Carefully select a pickup tool to avoid any damage during the SMT process.
- Do not make contact with the device when reworking or tuning components that are in close proximity to the device.

10.3.1 Baking

It is not necessary to bake the QCA6234 if the conditions specified in [Section 10.2](#) have not been exceeded.

It is necessary to bake the QCA6234 if any condition specified in [Section 10.2](#) has been exceeded. The baking conditions are specified on the moisture-sensitive caution label attached to each bag.

CAUTION: If baking is required, the devices must be transferred into trays that can be baked to at least 125°C. Devices should not be baked in tape and reel carriers at any temperature.

10.3.2 Electrostatic Discharge

Electrostatic discharge (ESD) occurs naturally in laboratory and factory environments. An established high-voltage potential is always at risk of discharging to a lower potential. If this discharge path is through a semiconductor device, destructive damage may result.

ESD countermeasures and handling methods must be developed and used to control the factory environment at each manufacturing site.

QTI products must be handled according to the *ESD Association standard: ANSI/ESD S20.20-1999, Protection of Electrical and Electronic Parts, Assemblies, and Equipment*.

Exhibit 1

PLEASE READ THIS LICENSE AGREEMENT (“AGREEMENT”) CAREFULLY. THIS AGREEMENT IS A BINDING LEGAL AGREEMENT ENTERED INTO BY AND BETWEEN YOU (OR IF YOU ARE ENTERING INTO THIS AGREEMENT ON BEHALF OF AN ENTITY, THEN THE ENTITY THAT YOU REPRESENT) AND QUALCOMM TECHNOLOGIES, INC. (“QTI” “WE” “OUR” OR “US”). THIS IS THE AGREEMENT THAT APPLIES TO YOUR USE OF THE DESIGNATED AND/OR ATTACHED DOCUMENTATION AND ANY UPDATES OR IMPROVEMENTS THEREOF (COLLECTIVELY, “MATERIALS”). BY USING OR COMPLETING THE INSTALLATION OF THE MATERIALS, YOU ARE ACCEPTING THIS AGREEMENT AND YOU AGREE TO BE BOUND BY ITS TERMS AND CONDITIONS. IF YOU DO NOT AGREE TO THESE TERMS, QTI IS UNWILLING TO AND DOES NOT LICENSE THE MATERIALS TO YOU. IF YOU DO NOT AGREE TO THESE TERMS YOU MUST DISCONTINUE AND YOU MAY NOT USE THE MATERIALS OR RETAIN ANY COPIES OF THE MATERIALS. ANY USE OR POSSESSION OF THE MATERIALS BY YOU IS SUBJECT TO THE TERMS AND CONDITIONS SET FORTH IN THIS AGREEMENT.

1.1 **License.** Subject to the terms and conditions of this Agreement, including, without limitation, the restrictions, conditions, limitations and exclusions set forth in this Agreement, Qualcomm Technologies, Inc. (“QTI”) hereby grants to you a nonexclusive, limited license under QTI’s copyrights to use the attached Materials; and to reproduce and redistribute a reasonable number of copies of the Materials. You may not use Qualcomm Technologies or its affiliates or subsidiaries name, logo or trademarks; and copyright, trademark, patent and any other notices that appear on the Materials may not be removed or obscured. QTI shall be free to use suggestions, feedback or other information received from You, without obligation of any kind to You. QTI may immediately terminate this Agreement upon your breach. Upon termination of this Agreement, Sections 1.2-4 shall survive.

1.2 **Indemnification.** You agree to indemnify and hold harmless QTI and its officers, directors, employees and successors and assigns against any and all third party claims, demands, causes of action, losses, liabilities, damages, costs and expenses, incurred by QTI (including but not limited to costs of defense, investigation and reasonable attorney’s fees) arising out of, resulting from or related to: (i) any breach of this Agreement by You; and (ii) your acts, omissions, products and services. If requested by QTI, You agree to defend QTI in connection with any third party claims, demands, or causes of action resulting from, arising out of or in connection with any of the foregoing.

1.3 **Ownership.** QTI (or its licensors) shall retain title and all ownership rights in and to the Materials and all copies thereof, and nothing herein shall be deemed to grant any right to You under any of QTI’s or its affiliates’ patents. You shall not subject the Materials to any third party license terms (e.g., open source license terms). You shall not use the Materials for the purpose of identifying or providing evidence to support any potential patent infringement claim against QTI, its affiliates, or any of QTI’s or QTI’s affiliates’ suppliers and/or direct or indirect customers. QTI hereby reserves all rights not expressly granted herein.

1.4 **WARRANTY DISCLAIMER.** YOU EXPRESSLY ACKNOWLEDGE AND AGREE THAT THE USE OF THE MATERIALS IS AT YOUR SOLE RISK. THE MATERIALS AND TECHNICAL SUPPORT, IF ANY, ARE PROVIDED “AS IS” AND WITHOUT WARRANTY OF ANY KIND, WHETHER EXPRESS OR IMPLIED. QTI ITS LICENSORS AND AFFILIATES MAKE NO WARRANTIES, EXPRESS OR IMPLIED, WITH RESPECT TO THE MATERIALS OR ANY OTHER INFORMATION OR DOCUMENTATION PROVIDED UNDER THIS AGREEMENT, INCLUDING BUT NOT LIMITED TO ANY WARRANTY OF MERCHANTABILITY OR FITNESS FOR A PARTICULAR PURPOSE OR AGAINST INFRINGEMENT, OR ANY EXPRESS OR IMPLIED WARRANTY ARISING OUT OF TRADE USAGE OR OUT OF A COURSE OF DEALING OR COURSE OF PERFORMANCE. NOTHING CONTAINED IN THIS AGREEMENT SHALL BE CONSTRUED AS (I) A WARRANTY OR REPRESENTATION BY QTI, ITS LICENSORS OR AFFILIATES AS TO THE VALIDITY OR SCOPE OF ANY PATENT, COPYRIGHT OR OTHER INTELLECTUAL PROPERTY RIGHT OR (II) A WARRANTY OR REPRESENTATION BY QTI THAT ANY MANUFACTURE OR USE WILL BE FREE FROM INFRINGEMENT OF PATENTS, COPYRIGHTS OR OTHER INTELLECTUAL PROPERTY RIGHTS OF OTHERS, AND IT SHALL BE THE SOLE RESPONSIBILITY OF YOU TO MAKE SUCH DETERMINATION AS IS NECESSARY WITH RESPECT TO THE ACQUISITION OF LICENSES UNDER PATENTS AND OTHER INTELLECTUAL PROPERTY OF THIRD PARTIES.

1.5 **LIMITATION OF LIABILITY.** IN NO EVENT SHALL QTI, QTI’S AFFILIATES OR ITS LICENSORS BE LIABLE TO YOU FOR ANY INCIDENTAL, CONSEQUENTIAL OR SPECIAL DAMAGES, INCLUDING BUT NOT LIMITED TO ANY LOST PROFITS, LOST SAVINGS, OR OTHER INCIDENTAL DAMAGES, ARISING OUT OF THE USE OR INABILITY TO USE, OR THE DELIVERY OR FAILURE TO DELIVER, ANY OF THE MATERIALS, OR ANY BREACH OF ANY OBLIGATION UNDER THIS AGREEMENT, EVEN IF QTI HAS BEEN ADVISED OF THE POSSIBILITY OF SUCH DAMAGES. THE FOREGOING LIMITATION OF LIABILITY SHALL REMAIN IN FULL FORCE AND EFFECT REGARDLESS OF WHETHER YOUR REMEDIES HEREUNDER ARE DETERMINED TO HAVE FAILED OF THEIR ESSENTIAL PURPOSE. THE ENTIRE LIABILITY OF QTI, QTI’S AFFILIATES AND ITS LICENSORS, AND THE SOLE AND EXCLUSIVE REMEDY OF YOU, FOR ANY CLAIM OR CAUSE OF ACTION ARISING HEREUNDER (WHETHER IN CONTRACT, TORT, OR OTHERWISE) SHALL NOT EXCEED US\$10.

2. **COMPLIANCE WITH LAWS; APPLICABLE LAW.** You agree to comply with all applicable local, international and national laws and regulations and with U.S. Export Administration Regulations, as they apply to the subject matter of this Agreement. This Agreement is governed by the laws of the State of California, excluding California’s choice of law rules.

3. **CONTRACTING PARTIES.** If the Materials are downloaded on any computer owned by a corporation or other legal entity, then this Agreement is formed by and between QTI and such entity. The individual accepting the terms of this Agreement represents and warrants to QTI that they have the authority to bind such entity to the terms and conditions of this Agreement.

4. **MISCELLANEOUS PROVISIONS.** This Agreement, together with all exhibits attached hereto, which are incorporated herein by this reference, constitutes the entire agreement between QTI and You and supersedes all prior negotiations, representations and agreements between the parties with respect to the subject matter hereof. No addition or modification of this Agreement shall be effective unless made in writing and signed by the respective representatives of QTI and You. The restrictions, limitations, exclusions and conditions set forth in this Agreement shall apply even if QTI or any of its affiliates becomes aware of or fails to act in a manner to address any violation or failure to comply therewith. You hereby acknowledge and agree that the restrictions, limitations, conditions and exclusions imposed in this Agreement on the rights granted in this Agreement are not a derogation of the benefits of such rights. You further acknowledges that, in the absence of such restrictions, limitations, conditions and exclusions, QTI would not have entered into this Agreement with You. Each party shall be responsible for and shall bear its own expenses in connection with this Agreement. If any of the provisions of this Agreement are determined to be invalid, illegal, or otherwise unenforceable, the remaining provisions shall remain in full force and effect. This Agreement is entered into solely in the English language, and if for any reason any other language version is prepared by any party, it shall be solely for convenience and the English version shall govern and control all aspects. If You are located in the province of Quebec, Canada, the following applies: The Parties hereby confirm they have requested this Agreement and all related documents be prepared in English.